

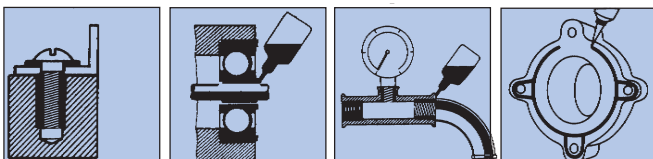

WEICON LOCK[®]

Anaerobic Adhesives and Sealants

- locking • retaining
- sealing • gasketing



The ideal solution for construction, production and maintenance:

- one-component • fast curing • ready-to-use
- solvent-free • non-shrinking • vibration-proof



Fig. 1
WEICONLOCK products are high quality anaerobic adhesives and sealants on the basis of special methacrylate resins, especially made for economical threadlocking, retaining and sealing of threaded, cylindrical and pipe assemblies.

The characteristic feature of WEICONLOCK is the curing in contact with metal while deprived of air. It provides a shock- and vibration-resistant joint with excellent resistance to chemicals and solvents. Due to its liquid consistency WEICONLOCK completely fills the gaps, thus giving protection against leakage and fretting corrosion.



Fig. 2
Special features and benefits

WEICONLOCK is simple, easy to use and very economical. Handling strength is reached within a few minutes and final strength within a few hours at room temperature. Metering and mixing is not necessary, there is no pot life to be respected and product wastage is minimised.

In many respects, WEICONLOCK is superior to conventional methods of assembly.

The use of WEICONLOCK®

- avoids expensive down-times
- reduces production costs
- improves operational reliability
- reduces assembly times

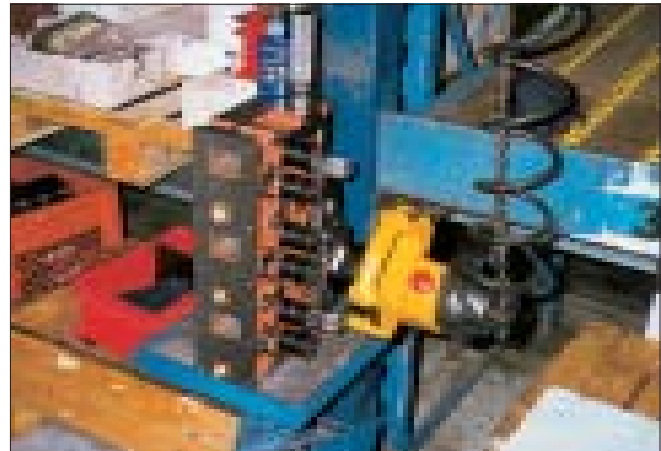

Fig. 3
Applications

Offering different grades of strength and viscosity, WEICONLOCK is suitable for a wide range of applications:

- for locking, fastening and sealing of screw connections from M5 to M80, for pipe joints as well as coarse threaded connections up to 3".
- for reliable retaining of bearings, bushings, bolts and other press or slip fitted connections.
- for sealing and locking hydraulic and pneumatic pipe connections.

In addition, WEICONLOCK is highly recommended for use in flange sealing, replacing conventional gaskets in many cases. The benefits are:

- no expensive stock keeping
- no problems with complicated seals
- no setting of the seals (unlike solid gaskets)

WEICONLOCK is suitable for all metals and certain plastics. It can be applied either manually or semi / fully automatic.

As cost-effective problem solvers, WEICONLOCK products are indispensable in many sectors of industry:

- automotive industry
- engine and plant construction
- manufacture of pumps and pipes
- hydraulic and pneumatic equipment
- precision mechanics
- in electrical engineering and electro-technics and in nearly all fields of repair and maintenance.

Fig. 1 Fitting for beer taps WEICONLOCK AN 305-86

Fig. 2 Solide coupling for use in farming fastened with WEICONLOCK AN 302-77

Fig.3 group of housings for motor construction fastened with WEICONLOCK AN 306-03

General Information

Pretreatment of Surface

In general, WEICONLOCK does not require special pretreatment as slightly oily surfaces (e.g. on 'as received' parts) will be tolerated. However, best results will be achieved on cleaned, degreased parts (use WEICON Cleaner S). If required, the parts should be slightly roughened.

Application

WEICONLOCK is ready for use and should be applied evenly direct from the bottle/tube with the dispensing tip (avoid direct contact of dispensing tip with metal). On pressfitted parts and larger cylindrical assemblies a thin and uniform layer should be applied on both surfaces. In the case of threaded blind holes fill sufficient quantity in the bore hole. On screws and bolts, apply WEICONLOCK around the thread.

Do not pour back into the bottle any WEICONLOCK fluid which had contact with metal; even smallest metal particles will cause the content of the bottle to cure. In series construction, the use of manual or automatic applicators is recommended.

Choice of product

WEICONLOCK is available in different categories of strength:

- low strength = easy dismantling
- medium strength = dismantling possible with ordinary tools
- high strength = cannot be dismantled mechanically other than by destruction

Different viscosity grades enable the locking of screws of smallest diameter up to M80/R3".

Active materials fast curing	Passive materials slower curing
bronze iron copper brass steel	high-alloyed steel aluminium nickel zinc gold oxide layers chromate layers anodic coatings plastics ceramics

WEICONLOCK Activator F

The cure time can considerably be reduced by pretreatment with WEICONLOCK Activator F, which is recommended for all passive surfaces and which is indispensable at low ambient temperatures (0°C and up) and for large gaps. On non-metallic surfaces, WEICONLOCK is made effective by use of the activator.

For applications where passive surfaces are involved, where the use of an Activator is not wanted yet where a rapid cure is required, a solution could be the use of types AN 302-60, AN 302-80, AN 306-10 and AN 306-30. These special types allow to reach handling strength much quicker than any standard type (without Activator).

Curing

WEICONLOCK remains liquid as long as in contact with air. The cure starts when WEICONLOCK, between the interfaces, comes into contact with metal under the absence of air. The cure time is dependent on the selected type, the ambient temperature and the material.



Fig. 1

Dismantling

Connections of low and medium strength can easily be loosened with ordinary tools; high-strength bonded parts can be disassembled by being heated to min. 300°C. Cured residues of WEICONLOCK can be removed mechanically or with "WEICON Sealant and Adhesive Remover".

Storage

WEICONLOCK can be stored in the unopened original container for at least one year at room temperature. Keep away from heat sources and direct sunlight. The air in the bottle/tube keeps WEICONLOCK liquid.



Fig. 2

Safety precautions

WEICONLOCK adhesives and sealants generally do not cause allergic reactions of the skin. However, in isolated cases where skin is continuously bruised or micro-lacerated sensitisation may occur. Therefore, extensive and direct contact with the skin should be avoided, e.g. by use of WEICON Hand Protective Foam. See further details in the Material Safety Data Sheets which are available upon request.

Fig. 1 threadlocking on ship engines WEICONLOCK AN 302-43

Fig. 2 easy-running aluminium-roller for rotary machines WEICONLOCK AN 306-38

Field of Application:
Retaining cylindrical assemblies

- shaft / hub-connections
- coupling hubs, pulleys, bearings
- cylindrical parts; slip-, press- or shrunk-fitted

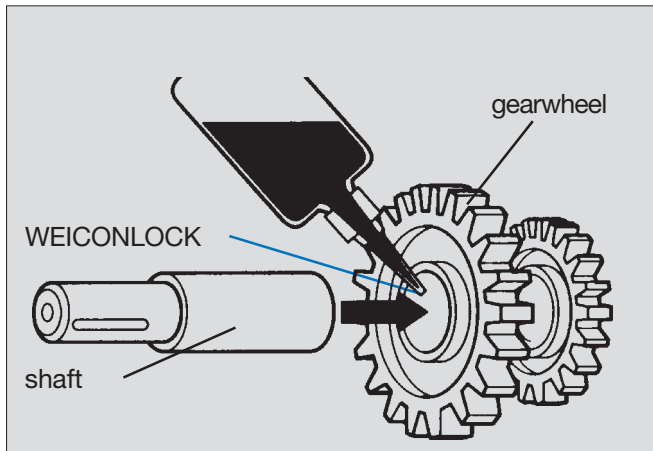

WEICONLOCK retaining adhesives fill the voids on smooth mating surfaces and thus provide total contact of the parts. Additional securing (e.g. by keys) will not be necessary and fretting corrosion will be avoided.

Further applications:
 Retention of ball-, roller- and slide bearings, bushes, bolts, liners, keys, splines and other close fitting parts

In many cases, WEICONLOCK enables the reconditioning of worn out fittings.

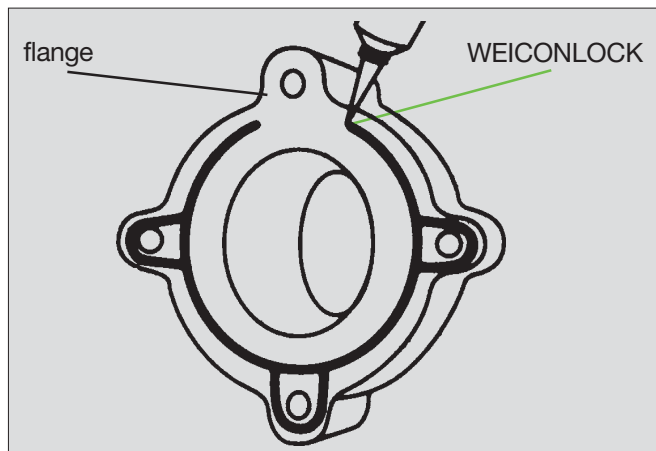

Fig. 1
 Combined methods of retaining (e.g bonding with WEICONLOCK in connection with shrunkfitting or pressfitting) allow to obtain a power transmission and torque strength higher than that for each of the two methods seperately.

The combination of bonding and securing by feather keys will prevent punctual load and fretting corrosion. No axial securing will be necessary in this case.

Field of Application:
Flange sealing, gasketing

- flanges
- cases
- lids



Sealing with solvent-free, liquid WEICONLOCK is an excellent technological solution. Unlike ordinary gaskets (paper, fibre or cork), WEICONLOCK sealant products will always fit the required size. They completely fills the voids of surfaces and guarantees total face-to-face contact. At low pressures (up to 6 bar), WEICONLOCK provides an instant seal.

Contrary to conventional gaskets, there is no setting of a WEICONLOCK-formed gasket. Due to high elasticity, WEICONLOCK flange sealants can be used under extreme conditions.



Fig. 2
 Cured WEICONLOCK products are resistant against most media (such as liquids and gases) used in industry.

Fig. 1 bottom bracket ball bearing of a bicycle fastened with WEICONLOCK AN 306-03
 Fig. 2 flange in a stump grubber sealed with WEICONLOCK AN 305-74



WEICON LOCK®

Anaerobic Adhesives and Sealants

- locking • retaining
- sealing • gasketing

Distributed by:



Fig. 1 Fitting of an underground drinking water main pipe: Threaded joint sealed and locked WEICONLOCK AN 306-38



Fig. 3 Manometer for testing and shut-off apparatus in water/gas supply: Fittings sealed with WEICONLOCK AN 302-43



Fig. 2 Low-voltage halogen lamps: Threadlocking on articulations and shanks with WEICONLOCK AN 302-70



Fig. 4 Three-way tap of petrol pump: Threadlocked with WEICONLOCK AN 306-38

309000119/036 DC

Type No.	Application	Viscosity* at +25°C in mPa • s Brookfield	Gap filling capacity in mm max.	For threaded joints up to	Colour	Temperature resistance from to
AN 302-21	Threadlocking, vibration-proof; low viscosity, low strength, easy disassembly	125	0,10	M 12	violet	-60 +150
AN 302-22	Threadlocking, vibration-proof; medium viscosity, low strength, easy disassembly	1.000 mt	0,20	M 36	purple	-60 +150
AN 302-41	Threadlocking; low viscosity, medium strength, disassembly with normal tools	125 lt	0,10	M 12	blue	-60 +150
AN 302-42	Threadlocking; medium viscosity, medium strength, disassembly with normal tools	1.000 mt	0,20	M 36	blue	-60 +150
AN 302-43	Universal threadlocking type; approved to DVGW ² /KTW ¹ , higher viscosity, medium strength, disassembly with normal tools	2.000 - 7.000 mt	0,25	M 36	blue	-60 +150
NEU AN 302-60	Threadlocking for passive materials such as stainless steel, aluminium, etc - fast bonding without activator; medium viscosity, high strength, hard to disassemble	700 - 1.000 lt	0,15	M 20 R ¾"	green	-60 +180
AN 302-62	Threadlocking; higher viscosity, high strength, hard to disassemble	1.500 - 6.500 mt	0,25	M 36	red	-60 +150
AN 302-70	Locking of threads and stud bolts; medium viscosity, high strength, hard to disassemble	500 lt	0,15	M 20 R ½"	green	-60 +150
AN 302-71	Locking of threads and stud bolts; medium viscosity, high strength, hard to disassemble	500 lt	0,15	M 20 R ½"	red	-60 +150
AN 302-72	Locking of threads and stud bolts; high-temperature resistant, higher viscosity, high strength, hard to disassemble	6.000 - 15.000 mt	0,30	M 56 R 2"	red	-60 +230
AN 302-90	Threadlocking, for locking after mounting and sealing of hair cracks; low viscosity, high strength, hard to disassemble	10 - 20	0,07	M 5 capillary	green	-60 +150
AN 302-25	Sealing of threaded pipes and fittings, vibration-proof; high viscosity, low strength, easy disassembly	6.000 - 30.000 mt	0,30	M 80 R 3"	brown	-60 +150
AN 302-45	Sealing of threaded pipes and fittings for coarse threaded connections; high viscosity, medium strength, disassembly with normal tools	6.000 - 30.000 mt	0,30	M 80 R 3"	blue	-60 +150
AN 302-75	Sealing of threaded pipes and fittings for coarse threaded parts and flanges; high viscosity, high strength, hard to disassemble	14.000 - 24.000 mt	0,30	M 80 R 3"	green	-60 +150
AN 302-77	Sealing of threaded pipes and fittings for coarse threaded parts and flanges; high viscosity, high strength, hard to disassemble	6.000	0,25	M 36	red	-60 +150
NEU AN 302-80	Sealing of threaded pipes and fittings for passive materials such as stainless steel, aluminium, etc - fast bonding without activator; higher viscosity, high strength, hard to disassemble	3.000 - 6.000 mt	0,20	M 36	green	-60 +180
AN 305-11	Sealing of threaded pipes and fittings; approved by DVGW ² /to KTW ¹ , higher viscosity, medium strength, disassembly with normal tools	17.000 - 50.000 ht	0,40	M 80 R 3"	white	-60 +150
AN 305-42	Sealing of hydraulic and pneumatic systems, universal product; medium viscosity, medium strength, disassembly with normal tools	500 lt	0,15	M 20 R ¾"	brown	-60 +150
AN 305-72	Pipe and flange sealing (with PTFE), instant seal, appr. by DVGW ² /to KTW ¹ ; high viscosity, medium strength, disassembly with normal tools	17.000 - 50.000 ht	0,40	M 80 R 3"	white	-60 +150
AN 305-77	Universal sealing type for pipes and fittings; BAM ³ approval for gaseous oxygen, high viscosity, medium strength, disassembly with normal tools	24.000 - 70.000 ht	0,50	M 80 R 3"	yellow	-60 +150
AN 305-86	Pipe sealing, extra strong higher viscosity, hard to disassemble	6.000 - 7.000 lt	0,30	M 56 R 2"	red	-60 +150
AN 306-01	Retaining cylindrical assemblies, low viscosity, high strength, hard to disassemble	125 lt	0,10	M 12	green	-60 +150
AN 306-03	Retaining cylindrical assemblies, low viscosity, high strength, hard to disassemble	125 lt	0,10	M 12	green	-60 +150
NEU AN 306-10	Retaining cylindrical assemblies, for passive materials such as stainless steel, aluminium, etc - fast bonding without activator; medium viscosity, high strength, hard to disassemble	700 - 1.000 lt	0,15	M 20 R ¾"	green	-60 +180
AN 306-20	Retaining cylindrical assemblies, approved by DVGW ² /to KTW ¹ , high-temperature resistant; higher viscosity, high strength, hard to disassemble	3.000 - 6.000 lt	0,20	M 56 R 2"	green	-60 +200
NEU AN 306-30	Retaining cylindrical assemblies, for passive materials such as stainless steel, aluminium, etc - fast bonding without activator; higher viscosity, high strength, hard to disassemble	3.000 - 6.000 mt	0,20	M 36	green	-60 +180
AN 306-38	Retaining cylindrical assemblies under high dynamical stress, fast-curing; medium viscosity, high strength, hard to disassemble	2.500 mt	0,20	M 36	green	-60 +150
AN 306-40	Retaining cylindrical assemblies, high-temperature resistant, slow-curing; medium viscosity, high strength, hard to disassemble	600 nt	0,15	M 20	green	-60 +200
AN 306-41	Retaining cylindrical assemblies, medium viscosity, medium strength, disassembly with normal tools	550 lt	0,12	M 20	yellow	-60 +150
AN 306-48	Retaining cylindrical assemblies, high-temperature resistant; medium viscosity, high strength, hard to disassemble	500 lt	0,15	M 20	green	-60 +175
NEU AN 306-60	Assembly of cylindrical parts; ideal for repair of worn out bearings, bushes and damaged seats of bearings as well as for larger gaps up to 0,5 mm. high viscosity, high strength, hard to disassemble	150.000 - 900.000 ht	0,50	R 2"	silver	-60 +150
AN 305-10	Gasketing of flanges, gearboxes and motor housings, high-temperature resistant; high viscosity, high strength, hard to disassemble	70.000 - 300.000 ht	0,50	—	orange	-60 +200
AN 305-18	Flange sealing and gasketing, large gap-filling with instant seal; high viscosity, high strength, hard to disassemble	80.000 - 500.000 ht	0,50	—	red	-60 +200
AN 305-72	Pipe and flange sealing (with PTFE), instant seal, appr. by DVGW ² /to KTW ¹ ; high viscosity medium strength, disassembly with normal tools	17.000 - 50.000 mt	0,40	M 80 R 3"	white	-60 +150
AN 305-73	Gasketing of flanges, gearboxes and motor housings, elastic; high viscosity, low strength, easy disassembly	17.000 - 50.000 mt	0,30	—	light green	-60 +150
AN 305-74	Gasketing of flanges, gearboxes and motor housings, universal type, high-temperature resistant; high viscosity, high strength, hard to disassemble	30.000 - 100.000 ht	0,50	—	orange	-60 +180

*Strength values based on M 10 screws, 8.8 grade, thickness of nut 0,8 d
 **Static shear strength based on cylindrical parts of abt. Ø 13 mm, tolerance (D - d) = 0,05 mm, l/d = 0,88
¹ KTW test (Technologiezentrum Wasser TZW Karlsruhe) for use in drinking water supply systems
² DVGW Certificate for use in gas supply and hot water systems
³ BAM Approval (Bundesanstalt für Materialforschung und -prüfung BAM Tgb.-No. 4045/96 - II 2402 for gaseous oxygen up to max. +60°C operating temperature and 10 bar oxygen pressure)
 We do not recommend WEICONLOCK for long-term use on connections of copper and its alloys if exposed to water of more than +40°C.
 All recommendations and technical data are based on laboratory tests and extensive experiences by users. They have been compiled with greatest care but we take no warranty of any kind and accept no liability for the results obtained.

* lt = low thixotrope mt = medium thixotrope ht = high thixotrope

General physical data

- WEICONLOCK (Liquid)**
- Density
 - pH-value
 - Flash point (ISO 2592)
 - Vapour pressure at +25°C
 - Solubility
 - Storage life at +20°C

approx. 1,1 g/cm³
 < 7
 > +100°C
 < 0,1 Torr
 in acetone and similar prod.
 approx. 12 month in original package

WEICONLOCK (Cured)

- Admissible surface pressure for high-strength types
- Modulus of elasticity
- Coefficient of elongation
- Coefficient of therm. conductivity
- Specific forward resistance
- Dielectric coefficient
- Dielectric strength
- Temperature of decomposition
- Chemically resistant against

approx. 450 N/mm² (65.000 PSI) (thickness below 0,08 mm)
 approx. 180 N/mm² (26.000 PSI) (thickness below 0,25 mm)
 approx. 1.400 N/mm² (200.000 PSI)
 approx. 280 N/mm² (40.000 PSI)
 approx. ca. 8 · 10⁻⁶ $\frac{m}{m \cdot ^\circ C}$
 approx. 0,2 $\frac{W}{m \cdot ^\circ C}$
 approx. 10¹⁵ Ohm • cm
 approx. 4
 approx. 10 kV/mm
 from approx. +250°C
 water, oil, fuel, organic solvents, refrigerants, gases

Technical Data WEICONLOCK®

Type No.	Application	Features	Colour	For threaded joints up to	Viscosity in mPa • s at +25°C Brookfield	Gap filling capacity in mm max.	Breakaway strength N/m (Gewinde*)	Prevailing strength N/m (Gewinde*)	Shear-strength** N/mm² (DIN 54452)	Handling strength at room temp. (minutes)	Final strength at room temp. (hours)	Temperature resistance in °C from to
AN 302-21	Threadlocking	low strength low viscosity	violet	M 12	125	0,10	7 - 10	3 - 6	4 - 7	10 - 20	3 - 6	-60 +150
AN 302-22	Threadlocking	low strength medium viscosity	purple	M 36	1.000mt	0,20	4 - 8	2 - 4	3 - 5	10 - 20	3 - 6	-60 +150
AN 302-41	Threadlocking	medium strength low viscosity	blue	M 12	125 lt	0,10	10 - 15	12 - 16	8 - 12	10 - 20	approx. 3	-60 +150
AN 302-42	Threadlocking	medium strength medium viscosity	blue	M 36	1.000 mt	0,20	14 - 18	5 - 8	8 - 12	10 - 20	3 - 6	-60 +150
AN 302-43	Threadlocking, KTW¹ approval	medium strength higher viscosity	blue	M 36	2.000 - 7.000 mt	0,25	17 - 22	8 - 12	9 - 13	10 - 20	1 - 3	-60 +150
NEU AN 302-60	Threadlocking for passive materials - fast bonding without activator	high strength medium viscosity	green	M 20 R ¾"	700 - 1.000 lt	0,15	30 - 35	55 - 70	25 - 35	2 - 5	2 - 4	-60 +180
AN 302-62	Threadlocking	solid higher viscosity	red	M 36	1.500 - 6.500 mt	0,25	20 - 25	40 - 55	10 - 15	10 - 20	3 - 6	-60 +150
AN 302-70	Locking of threads and stud bolts	high strength medium viscosity	green	M 20 R ½"	500 lt	0,15	28 - 35	50 - 65	15 - 20	10 - 20	3 - 6	-60 +150
AN 302-71	Locking of threads and stud bolts	high strength medium viscosity	red	M 20 R ½"	500 lt	0,15	28 - 35	50 - 65	15 - 20	10 - 20	3 - 6	-60 +150
AN 302-72	Locking of threads and stud bolts, high temperature resistant	high strength higher viscosity	red	M 56 R 2"	6.000 - 15.000 mt	0,30	20 - 30	40 - 75	10 - 15	20 - 40	5 - 10	-60 +230
AN 302-90	Threadlocker for locking after assembly	high strength extrem low viscosity	green	M 5 capillary	10 - 20	0,07	15 - 25	30 - 40	8 - 12	5 - 20	approx. 3	-60 +150
AN 302-25	Sealing of threaded pipes and fittings	low strength high viscosity	brown	M 80 R 3"	6.000 - 30.000 mt	0,30	5 - 8	2 - 4	3 - 5	15 - 30	3 - 6	-60 +150
AN 302-45	Sealing of threaded pipes and fittings	medium strength high viscosity	blue	M 80 R 3"	6.000 - 30.000 mt	0,30	10 - 15	12 - 18	8 - 12	15 - 30	3 - 6	-60 +150
AN 302-75	Sealing of threaded pipes and fittings	high strength high viscosity	green	M 80 R 3"	14.000 - 24.000 mt	0,30	40 - 50	40 - 50	15 - 25	15 - 30	3 - 6	-60 +150
AN 302-77	Sealing of threaded pipes and fittings	high strength higher viscosity	red	M 36	6.000	0,25	30 - 40	10 - 15	35 - 45	40 - 60	6 - 12	-60 +150
NEU AN 302-80	Sealing of threaded pipes and fittings for passive materials - fast bonding without activator	high strength higher viscosity	green	M 36	3.000 - 6.000 mt	0,20	35 - 45	50 - 70	20 - 30	2 - 5	2 - 4	-60 +180
AN 305-11	Sealing of threaded pipes and fittings, DVGW²/KTW¹ approval	medium strength high viscosity	white	M 80 R 3"	17.000 - 50.000 ht	0,40	7 - 10	2 - 4	4 - 6	20 - 40	5 - 10	-60 +150
AN 305-42	Sealant for hydraulic and pneumatic systems	medium strength medium viscosity	brown	M 20 R ¾"	500lt	0,15	12 - 15	18 - 22	8 - 12	10 - 20	2 - 4	-60 +150
AN 305-72	Pipe and flange sealing (with PTFE), DVGW²/KTW¹ approval	medium strength high viscosity	white	M 80 R 3"	17.000 - 50.000 ht	0,40	7 - 10	2 - 4	4 - 6	20 - 40	5 - 10	-60 +150
AN 305-77	Sealing of threaded pipes and fittings, BAM³ approval	medium strength high viscosity	yellow	M 80 R 3"	24.000 - 70.000 ht	0,50	18 - 22	10 - 14	6 - 13	15 - 30	1 - 3	-60 +150
AN 305-86	Pipe sealing (extra strong)	high strength higher viscosity	red	M 56 R 2"	6.000 - 7.000 lt	0,30	15 - 30	25 - 45	10 - 20	60 - 90	12 - 24	-60 +150
AN 306-01	Retaining cylindrical assemblies	high strength low viscosity	green	M 12	125 lt	0,10	25 - 30	50 - 60	18 - 23	10 - 20	2 - 4	-60 +150
AN 306-03	Retaining cylindrical assemblies	high strength low viscosity	green	M 12	125 lt	0,10	25 - 30	50 - 60	15 - 18	10 - 20	2 - 4	-60 +150
NEU AN 306-10	Retaining cylindrical assemblies, for passive materials - fast bonding without activator	high strength medium viscosity	green	M 20 R ¾"	700 - 1.000 lt	0,15	30 - 35	55 - 70	25 - 35	2 - 5	2 - 4	-60 +180
AN 306-20	Retaining cylindrical assemblies, DVGW²/KTW¹ approval	high strength higher viscosity	green	M 56 R 2"	3.000 - 6.000 lt	0,20	28 - 36	40 - 55	15 - 25	20 - 40	approx. 24	-60 +200
NEU AN 306-30	Retaining cylindrical assemblies, for passive materials - fast bonding without activator	high strength higher viscosity	green	M 36	3.000 - 6.000 mt	0,20	35 - 45	50 - 70	20 - 30	2 - 5	2 - 4	-60 +180
AN 306-38	Retaining cylindrical assemblies	high strength medium viscosity	green	M 36	2.500 mt	0,20	35 - 45	50 - 70	25 - 30	approx. 5	1 - 3	-60 +150
AN 306-40	Retaining cylindrical assemblies, high-temperature resistant	high strength medium viscosity	green	M 20	600 lt	0,15	20 - 30	30 - 40	15 - 30	approx. 4 hours	approx. 24	-60 +200
AN 306-41	Retaining cylindrical assemblies	medium strength medium viscosity	yellow	M 20	550 lt	0,12	12 - 15	17 - 22	8 - 12	10 - 20	3 - 6	-60 +150
AN 306-48	Retaining cylindrical assemblies, high-temperature resistant	high strength medium viscosity	green	M 20	500 lt	0,15	30 - 35	55 - 70	25 - 35	approx. 5	2 - 4	-60 +175
NEU AN 306-60	Assembly of cylindrical parts; ideal for repair of worn out bearings	high strength high viscosity	silver	R 2"	150.000 - 900.000 ht	0,50	35 - 45	10 - 20	25 - 30	15 - 30	3 - 6	-60 +150
AN 305-10	Flange sealing, gasketing high-temperature resistant	high strength high viscosity	orange	---	70.000 - 300.000 ht	0,50	18 - 25	15 - 25	5 - 10	15 - 30	6 - 12	-60 +200
AN 305-18	Flange sealing, gasketing high-temperature resistant	high strength high viscosity	red	---	80.000 - 500.000 ht	0,50	12 - 18	18 - 24	8 - 13	10 - 20	3 - 6	-60 +200
AN 305-72	Pipe and flange sealing (with PTFE), DVGW²/KTW¹ approval	medium strength high viscosity	white	M 80 R 3"	17.000 - 50.000 mt	0,40	7 - 10	2 - 4	4 - 6	20 - 40	5 - 10	-60 +150
AN 305-73	Flange sealing, gasketing easy disassembly	low strength high viscosity	light green	---	17.000 - 50.000 mt	0,30	6 - 10	2 - 5	4 - 6	20 - 40	approx. 12	-60 +150
AN 305-74	Flange sealing, gasketing high-temperature resistant	high strength high viscosity	orange	---	30.000 - 100.000 ht	0,50	16 - 24	5 - 10	5 - 10	15 - 30	approx. 12	-60 +180

*Strength values based on M 10 screws, 8.8 grade, thickness of nut 0,8 d

**Static shear strength based on cylindrical parts of abt. Ø 13 mm, tolerance (D - d) = 0,05 mm, l/d = 0,88